

MICROOFFICE



SILENT LAB



UNIQ
PRIME
CUBIQ
QUADRIO

ICONIC DESIGN

REVOLUTIONARY VENTILATION SYSTEM

VIRTUALLY SOUNDPROOF

SOPHISTICATED DETAILS

TOP-TIER MATERIALS

MICROOFFICE



CONCEPT

MICROOFFICE is an ode to minimalism in the shape of an independent workspace. It is the bridge between the two halves of its environment, creating a private and peaceful inner world in the center of the chaos around it. These two realms are linked through vision, energy, light and sensation.

The MICROOFFICE design approach is one of duality, an act of balance between fundamental principles – body and space, transparent and unobtrusive, unyielding yet soft, intimate yet open.

The interior space is ensconced on all sides by a solid shell. The resulting object is opaque from one point of view, a tangible barrier dividing two worlds. From another perspective, it is nearly invisible as it merges with its surroundings. The glass ceilings of the UNIQ and larger QUADRIO models bathe the occupant in soothing natural light.

We've selected the materials used to create MICRO-OFFICE with great care. As a result, the serene design reflects both the simplicity and power contained within our concept.

ACOUSTICS

MICROOFFICE is an answer to the basic question of acoustic comfort. Layers of solid wood and acoustic materials, along with sound-insulating glass, a sonically sealed door and a silent ventilation system, make for maximum soundproofing between the interior and exterior spaces.

The extensive surface area provides optimal distribution of acoustic materials, leading to the creation of a quiet, pleasant interior environment. The entire structure has been calibrated to counter the specific frequencies of the human voice, making it an ideal setting for phone or conference calls.



MATERIAL

Our choice of materials reflects our commitment to the dual principles of MICROOFFICE. As such, we've upholstered the entire solid shell, while the transparent glass insulates against sound on both sides.

Horizontal divisions across the upholstered surfaces connote scale, while hand-crafted details around the border of each piece add subtle elegance. The entire structure is inspired by the ideal ergonomic height for a table or bar stools.

Design accents and interior accessories are carved from solid oak.

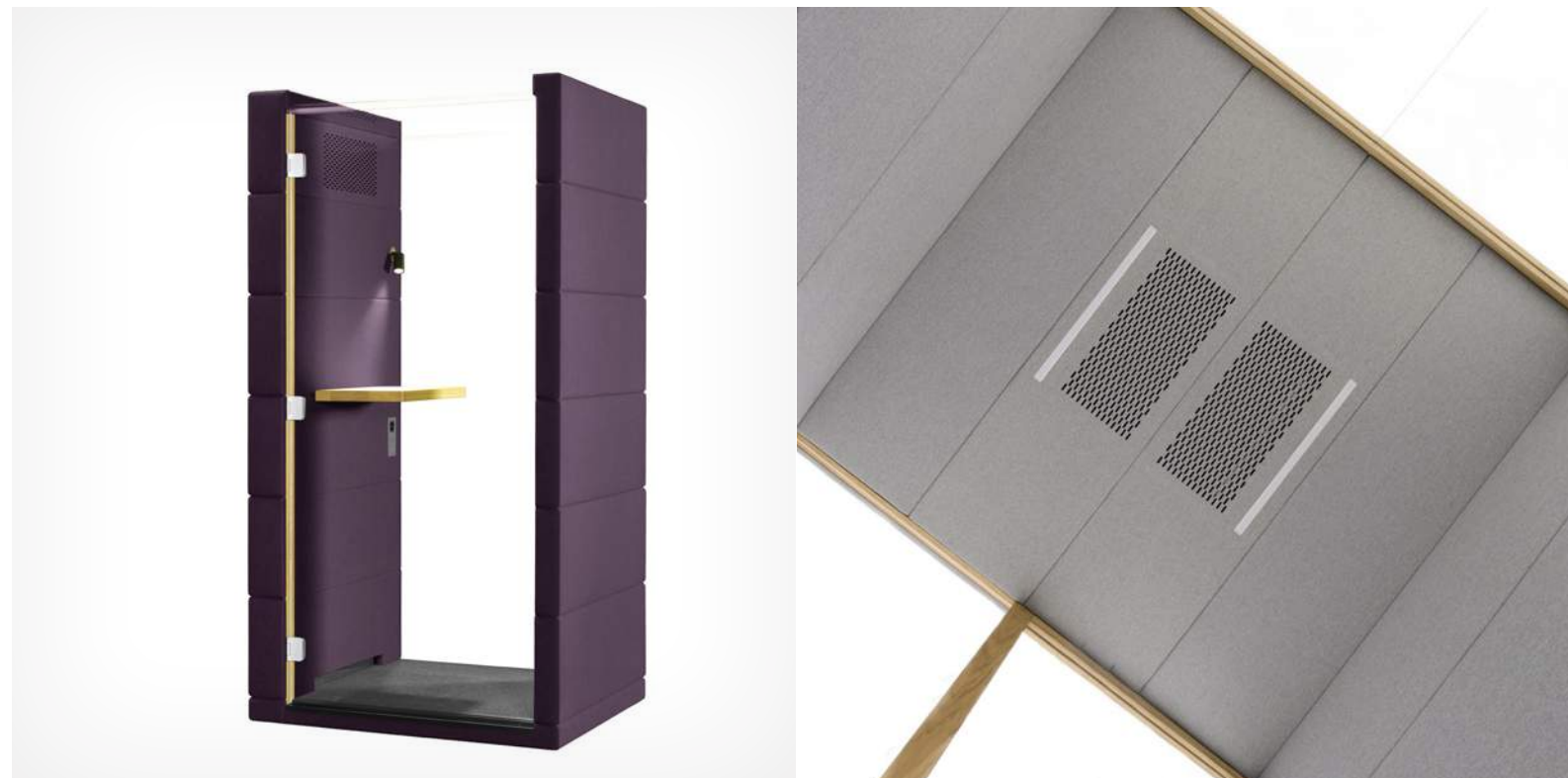

DESIGN

Based on the above principles, the concept and features mesh in perfect harmony. On two sides, solid facades protect the user from the most persistent sources of noise. The reassuring back wall evokes a feeling of security, while the opaque front eliminates visual distractions.

The other faces are made entirely of sound-insulating glass. The solid walls protruding above the ceiling create the unmistakably iconic "U" shape of the MICRO-OFFICE UNIQ.

TECHNOLOGY

Central to the MICROOFFICE experience is its cutting-edge ventilation system. Exclusive to our product family, this completely new innovation promises untold levels of comfort. With ultra-efficient ventilation supplying a constant stream of fresh air, users can enjoy the distraction-free solitude of our revolutionary workspaces for hours on end.

Each MICROOFFICE unit comes fully equipped with everything needed to perform at optimal levels. Electrical sockets, USB and LAN connections and an LED light are standard across the entire product line.

UNIQ

MICROOFFICE

MICROOFFICE UNIQ is the clear choice for combining true silence with active teamwork. The unparalleled design enables you to focus on crucial tasks right at the heart of the action. This dynamic workstation blends naturally into the surrounding environment, improving acoustics wherever it's placed.



reddot design award
winner 2019

TECHNICAL DETAILS



exterior dimensions	1200 x 1000 x 2320 mm / 47 x 39 x 91 in
interior dimensions	950 x 930 x 2150 mm / 37 x 37 x 85 in
weight	350 kg / 770 lbs
glass walls	sound-insulating glass
solid walls	sound-absorbing sandwich panel with acoustic insulation
glass wall frame and door handle	solid oak (natural/black)
ceiling	sound-insulating glass
flooring	carpet (anthracite grey)
ventilation	automatic/manual
lighting	LED
included equipment	desk (two height options: sitting/standing), electric socket (different country versions available) and USB connection
optional equipment	seat (barstool, chair)
color options	decorative fabric (refer to swatches)

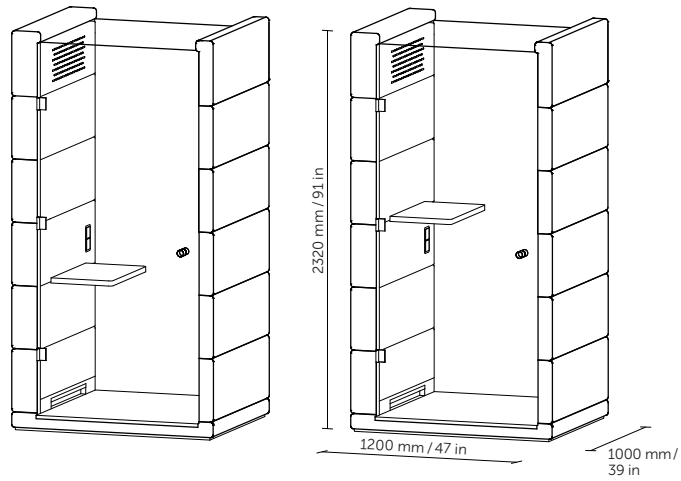

PRIME

MICROOFFICE

MICROOFFICE PRIME is a standalone haven of silence ready for use without any burdensome installation or renovation. It combines our iconic visual aesthetic with a unique ventilation system, high-end acoustic materials, sophisticated details and practical design.



TECHNICAL DETAILS

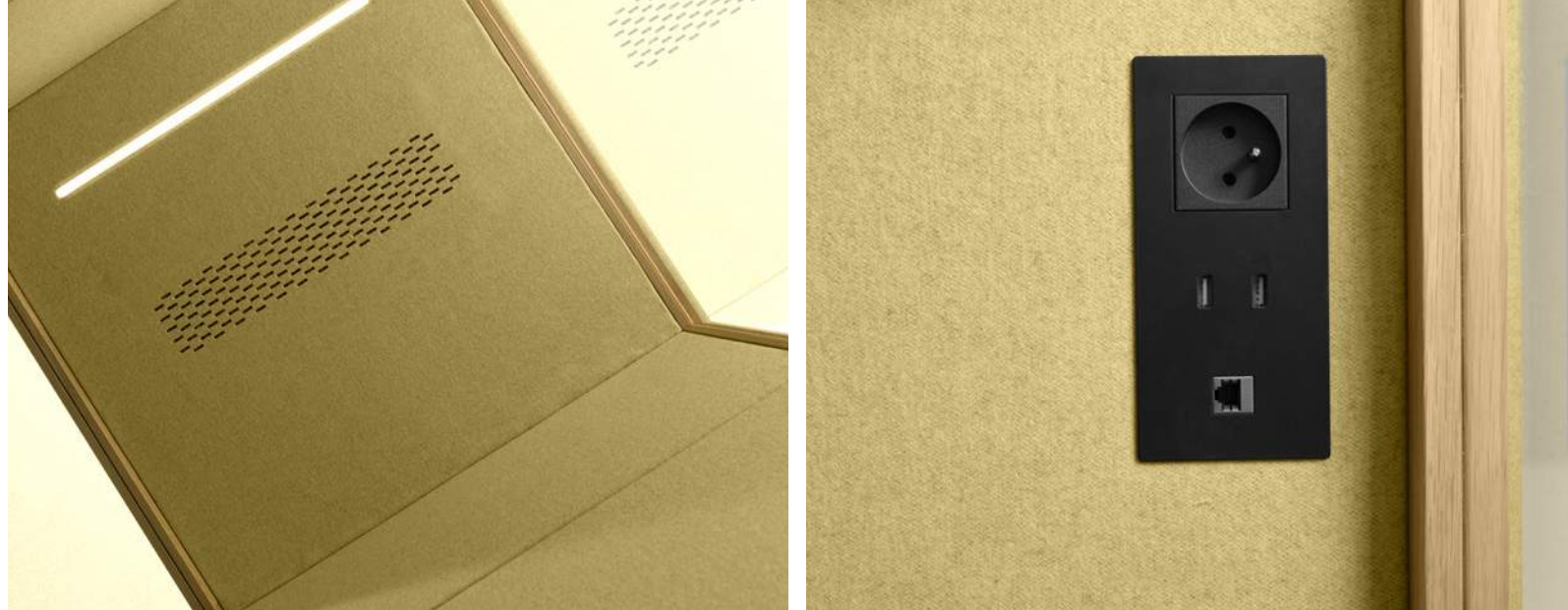

exterior dimensions	1150 x 1000 x 2270 mm / 45 x 39 x 89 in
interior dimensions	900 x 930 x 2150 mm / 35 x 37 x 85 in
weight	350 kg / 770 lbs
glass walls	sound-insulating glass
solid walls	sound-absorbing sandwich panel with acoustic insulation
glass wall frame and door handle	solid oak
ceiling	sound-absorbing sandwich panel with acoustic insulation
flooring	carpet (anthracite grey)
ventilation	automatic/manual
lighting	LED
included equipment	desk (two height options: sitting/standing), electric socket (different country versions available) and USB connection
optional equipment	seat (barstool, chair)
color options	decorative fabric (refer to swatches)

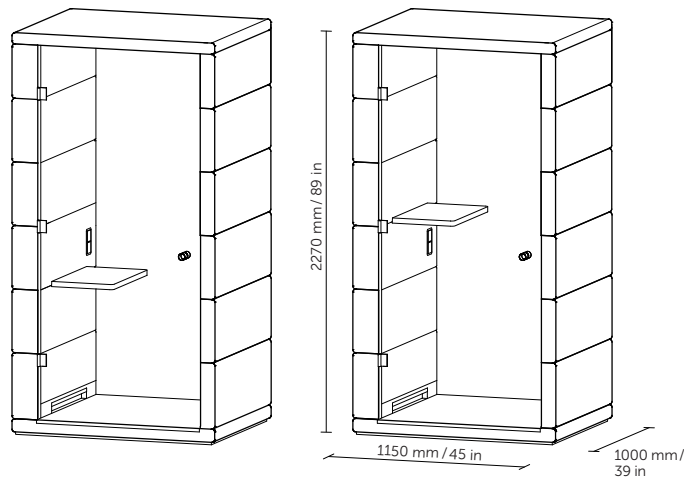

CUBIQ

MICROOFFICE

MICROOFFICE CUBIQ turns any area into a private multi-person meeting room. Enjoy unprecedented flexibility with two-person to four-person standing configurations.



reddot design award
winner 2019

TECHNICAL DETAILS



exterior dimensions	1780 x 1600 x 2270 mm / 70 x 63 x 89 in
interior dimensions	1560 x 1490 x 2090 mm / 61 x 59 x 82 in
weight	600 kg / 1322 lbs
glass walls	sound-insulating glass
solid walls	sound-absorbing sandwich panel with acoustic insulation
glass wall frame and door handle	solid oak
ceiling	sound-absorbing sandwich panel with acoustic insulation
flooring	carpet (anthracite grey)
ventilation	automatic/manual
lighting	LED
included equipment	electric socket (different country versions available) and USB connection
optional equipment	seats, desk/tree trunk (oak)
color options	decorative fabric (refer to swatches)

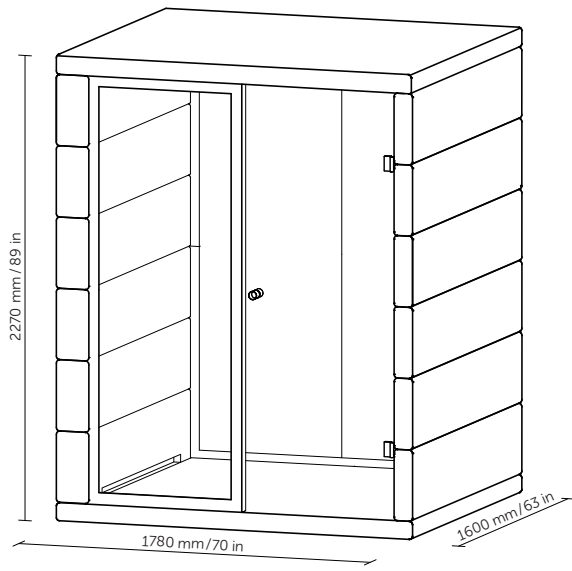



QUADRIO

MICROOFFICE

Find unlimited possibilities and forward-thinking design with MICROOFFICE QUADRIO, which you can configure exactly the way you need it. Our original concept, based on a segmented folding system of individual parts, allows you to create a tailor-made office for up to eight people.



QUADRIO I

TECHNICAL DETAILS



exterior dimensions	2520 x 1320 x 2270 mm / 99 x 52 x 89 in
interior dimensions	2245 x 1200 x 2150 mm / 88 x 47 x 85 in
weight	625 kg / 1378 lbs
glass walls	sound-insulating glass
solid walls	sound-absorbing sandwich panel with acoustic insulation
glass wall frame and door handle	solid oak
ceiling	sound-absorbing sandwich panel with acoustic insulation
flooring	carpet (anthracite grey)
ventilation	automatic/manual
lighting	LED
included equipment	electric socket (different country versions available) and USB connection
optional equipment	desk, seats
color options	decorative fabric (refer to swatches)

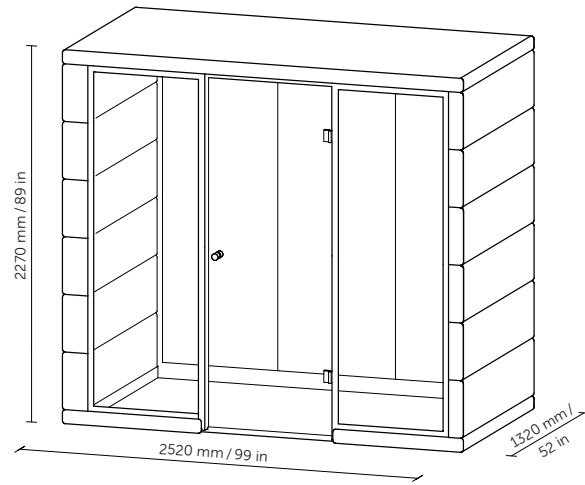

QUADRIO II

TECHNICAL DETAILS



exterior dimensions	2520 x 1944 x 2270 mm / 99 x 77 x 89 in
interior dimensions	2245 x 1854 x 2150 mm / 88 x 73 x 85 in
weight	750 kg / 1653 lbs
glass walls	sound-insulating glass
solid walls	sound-absorbing sandwich panel with acoustic insulation
glass wall frame and door handle	solid oak
ceiling	sound-absorbing sandwich panel with acoustic insulation
flooring	carpet (anthracite grey)
ventilation	automatic/manual
lighting	LED
included equipment	electric socket (different country versions available) and USB connection
optional equipment	desk, seats
color options	decorative fabric (refer to swatches)

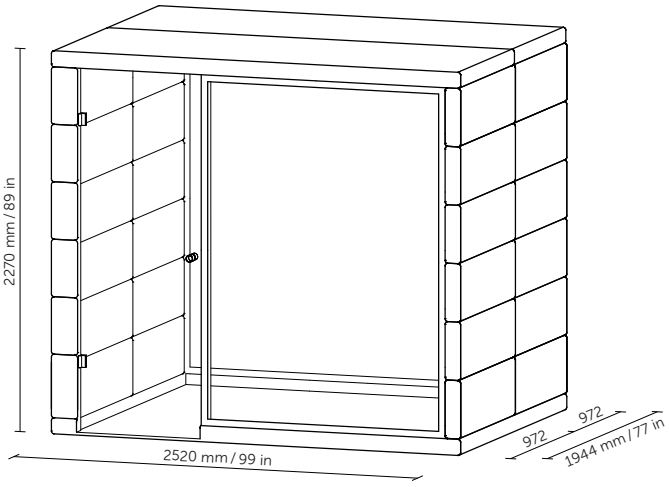

QUADRIO III

TECHNICAL DETAILS



exterior dimensions	2520 x 2856 x 2270 mm / 99 x 113 x 89 in
interior dimensions	2245 x 2766 x 2150 mm / 88 x 109 x 85 in
weight	950 kg / 2095 lbs
glass walls	sound-insulating glass
solid walls	sound-absorbing sandwich panel with acoustic insulation
glass wall frame and door handle	solid oak
ceiling	sound-absorbing sandwich panel with acoustic insulation and sound-insulating glass
flooring	carpet (anthracite grey)
ventilation	automatic/manual
lighting	LED
included equipment	electric socket (different country versions available) and USB connection
optional equipment	desk, seats
color options	decorative fabric (refer to swatches)

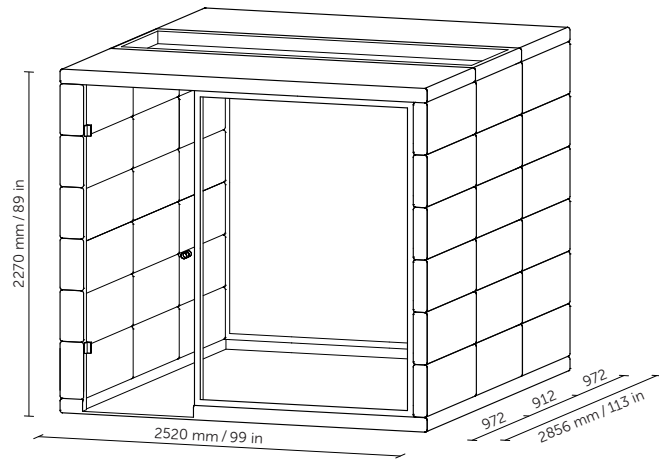

QUADRIO IV

TECHNICAL DETAILS



exterior dimensions	2520 x 3768 x 2270 mm / 99 x 148 x 89 in
interior dimensions	2245 x 3678 x 2150 mm / 88 x 145 x 85 in
weight	1150 kg / 2535 lbs
glass walls	sound-insulating glass
solid walls	sound-absorbing sandwich panel with acoustic insulation
glass wall frame and door handle	solid oak
ceiling	sound-absorbing sandwich panel with acoustic insulation and sound-insulating glass
flooring	carpet (anthracite grey)
ventilation	automatic/manual
lighting	LED
included equipment	electric socket (different country versions available) and USB connection
optional equipment	desk, seats
color options	decorative fabric (refer to swatches)

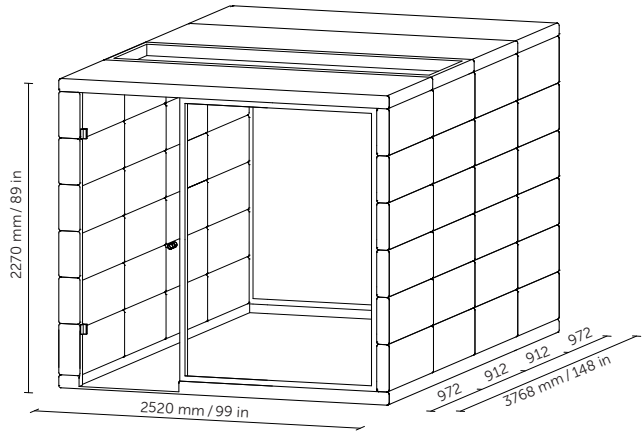

FABRIC SWATCHES

WOOLLAND

TECHNICAL DETAILS

materials	70% wool, 30% polyamide
weight	400 g/m ²
width	140 cm
abrasion resistance	> 100,000



W76

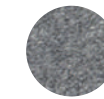

W36



W19

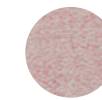

W03

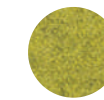

W08

BLAZER

TECHNICAL DETAILS

materials	100% virgin wool
weight	460 g/m ²
width	140 cm
abrasion resistance	> 50,000

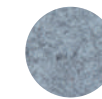

BL1R

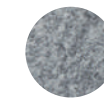

BL1E

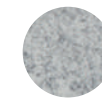

BL28

SYNERGY

TECHNICAL DETAILS

materials	95% virgin wool, 5% polyamide
weight	400 g/m ²
width	140 cm
abrasion resistance	> 100,000

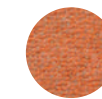

SY83

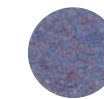

SY64

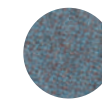

SY56

The colors displayed above are our recommended choices. For alternate options, please consult our comprehensive fabric collection.





CONTACT INFORMATION

+420 723 228 040

info@silent-lab.com

www.silent-lab.com

COMPANY ADDRESS

SilentLab s.r.o

Za Zastavkou 373

111 01 Prague – Czech Republic

The final product configuration
may differ from the versions
shown in the photographs.

All MICROOFFICE products are patent pending.

SilentLab®, MICROOFFICE® and their logos
are registered trademarks of SilentLab s.r.o.



SILENT LAB

ACOUSTICS THAT WORKS